

MEDACO[®]

support | equip | service

 **COVID-19 Healthcare Supplier Directory**
April 2020



Introduction

Medaco Ltd supply a range of specialist equipment to the NHS, Care Homes and special schools throughout the UK and in response to the COVID-19 crisis, we thought it might be useful for our healthcare customers to be able to access a directory which showcases a range of companies that manufacture and supply products that can support COVID-19 care. To find out more, you can click through to each company website, call or email them.

Medaco is continuing to support our healthcare and care home customers, doing all we can to supply what's needed during the next few months and beyond. For more information on our range of products and how we can help please contact us.



Disclaimer

Please be aware that the availability and prices of products mentioned within this directory may be subject to change. If you require any further information please contact the relevant supplier. We will do all we can to help.

Company Index



Coveya

☎ 0800 915 9195
 🌐 www.coveya.co.uk
 ✉ sales@coveya.co.uk

[View Listing ▶](#)



Decorquip Ltd

☎ 0290 880 811
 🌐 www.decorquip.com
 ✉ sales@decorquip.com

[View Listing ▶](#)



Ezi Klamp Systems Ltd

☎ 0117 970 2420
 🌐 www.ezijklampsystems.com
 ✉ sales@ezijklampsystems.com

[View Listing ▶](#)



Kensington Systems Ltd

☎ 0117 958 9933
 🌐 www.kensingtonsystems.co.uk
 ✉ sales@kensingtonsystems.co.uk

[View Listing ▶](#)



Medaco

☎ 033 33 22 33 44
 🌐 www.medaco.co.uk
 ✉ sales@medaco.co.uk

[View Listing ▶](#)



Regal Balustrades Ltd

☎ 0117 935 3888
 🌐 www.regalbalustrades.co.uk
 ✉ sales@regalbalustrades.co.uk

[View Listing ▶](#)



Swanmac

☎ 02920 811 458
 🌐 www.swanmac.co.uk
 ✉ sales@swanmac.co.uk

[View Listing ▶](#)



Unisan Ltd

☎ 0330 700 6000
 🌐 www.unisanuk.com
 ✉ sales@unisanuk.com

[View Listing ▶](#)



Umbr

☎ 01792 562 015
 🌐 www.umbrashading.co.uk
 ✉ sales@umbrashading.co.uk

[View Listing ▶](#)



WSG Interior Systems Ltd

☎ 07990080262
 🌐 www.wsginteriors.co.uk
 ✉ r.anderson@wsginteriors.co.uk

[View Listing ▶](#)

Product Index



Disposable Face Shield.....	Page 1
COV-Screen.....	Page 2
ONGARD GS (Guard Screen Systems).....	Page 3
ScreenLok.....	Page 4
Temporary Privacy Screen.....	Page 5
Room divider and cubicle track systems/disposable cubicle curtains.....	Page 6
Spaceshade canopy systems.....	Page 7
Ezi Klamp Free Standing Demarcation Barrier.....	Page 8
CONVERTADEK.....	Page 9
Body bags.....	Page 10
Longopac Continuous Liner System.....	Page 11
Hand & Surface Sanitiser stations.....	Page 12
ProfilGate Aqua - Mobile Footwear.....	Page 13
Emergency Field Bed.....	Page 14
Casa Med Classic Nursing Bed.....	Page 15
Casa Med Low Nursing Bed.....	Page 16
Bariatric Profiling Bed - Pro Bario.....	Page 17
Bedside Cabinet.....	Page 18
Disposable Patient Slings.....	Page 19
Liko 200 Ceiling Track Hoist.....	Page 20
FreeSpan Gantry Hoist System.....	Page 21
Advance Mobile Hoist.....	Page 22
Journey Standaid.....	Page 23
Glideabout Commode.....	Page 24
Ben NH Car Transit Wheelchair.....	Page 25
Deluxe Drip Stand.....	Page 26



Medaco

☎ 033 33 22 33 44
🌐 <https://www.medaco.co.uk>
✉ sales@medaco.co.uk

Disposable Face Shield >

Key Features:

- Fixed plastic bracket with clear visor
- Provides protection against foreign particles, chemical splash and dust
- CE EN14683:2005



Please Note: Mask is not included with the shield.



7-10
Working Days



POA



Inclusive
For orders of 500+ units

Certifications:

ISO 9001 2015
Achilles UVDB



Coveya

☎ 0117 956 3131
 🌐 <https://www.coveya.co.uk>
 ✉ sales@coveya.co.uk

[COV-Screen >](#)

Cov-Screen is the perfect solution for hospitals, surgeries, care homes, pharmacies, reception areas and other outlets that need to mitigate the impact of COVID-19. It's a quality, cost effective freestanding or fixed acrylic screen. Made by Coveya, who have a reputation for design and manufacturing excellence. Its features include:

Key Features:

- A robust clear acrylic screen
- Very light at 17kg
- Optional castors for ease of movement
- Includes a joining kit so any screen can be safely and securely joined at the edge to create longer barriers



5-7 Days



£290.00

2m Screen

£336.00

2m Screen on casters



£25

POA for multiple orders

Certifications:

- ISO 9001 2015
- CHAS
- Safe Contractor
- SMAS
- Greenlight



REGAL BALUSTRADES LTD

- ☎ 0117 9353888
- 🌐 <https://www.regalbalustrades.co.uk>
- ✉ sales@regalbalustrades.co.uk

ONGARD GS (Guard Screen Systems) >

ONGARD GS is a range of innovative screen guard systems designed to be fully modular and easy to install using basic equipment. The pre-assembled aluminium posts have a plain aluminium anodized finish and come ready to install.

*Due to different nature of surface materials, fixings are not included.

Key Features:

- Fully assembled posts
- Plain aluminium anodized finish
- To suit 10mm Perspex
- Suitable for indoor and outdoor application
- Quick, safe and easy installation
- 1200mm post centres (maximum)
- Posts available in top mount or side mount

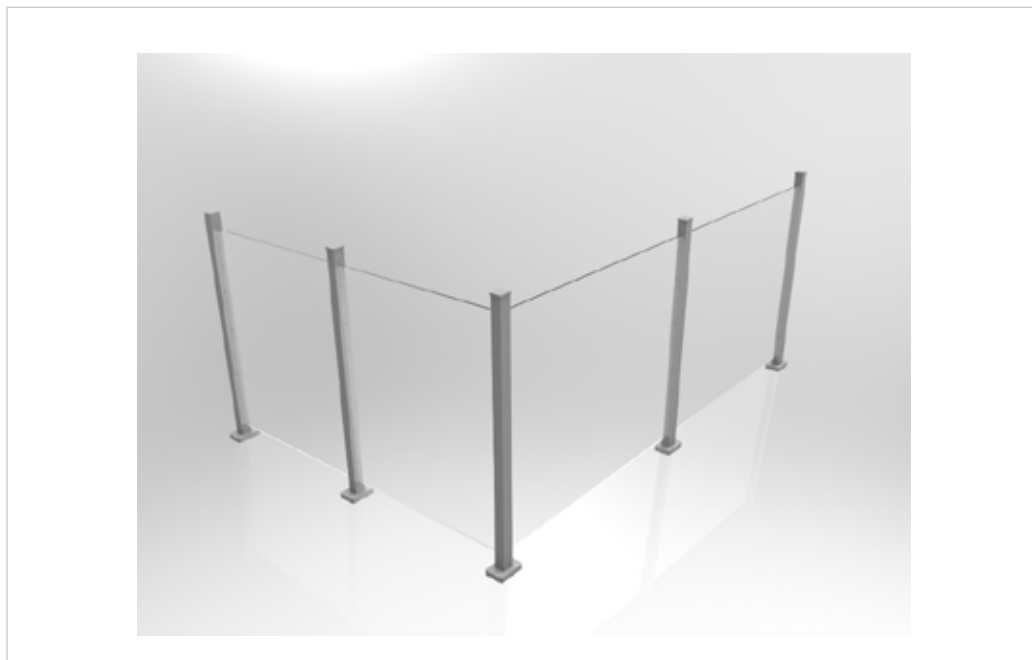

3-4 days



POA



POA

Certifications:

ISO 9001
ISO 14001



Umbr

☎ 01792 562015
 🌐 <https://www.umbrashading.co.uk>
 ✉ sales@umbrashading.co.uk

ScreenLok >

A flexible and versatile screening solution that can be rapidly deployed and easily reconfigured. Using fabric-retaining technology, ScreenLok is a fixed fabric screen with a multitude of partitioning uses.

Key Features:

- The screens are hygienic and easy to clean, making them perfect for patient privacy and prevention of cross-infection in healthcare environments. Contaminated fabrics panels can be removed for cleaning or replaced completely
- ScreenLok is perfect for temporary installations and occupies very little storage space in between uses. No special skills are required to assemble or dismantle, making this a solution for every situation
- Screens can be manufactured to bespoke sizes to fit your particular requirements. Just tell us what you need and we'll be happy to design a made-to-measure solution

Thanks to the stable, low-profile foot design, units can be used side-by-side or at right angles with virtually no gaps.

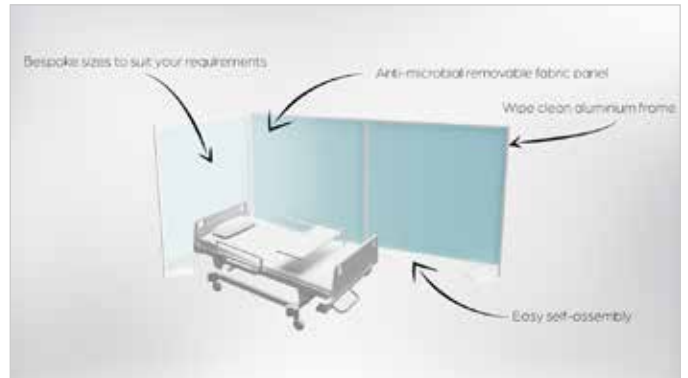
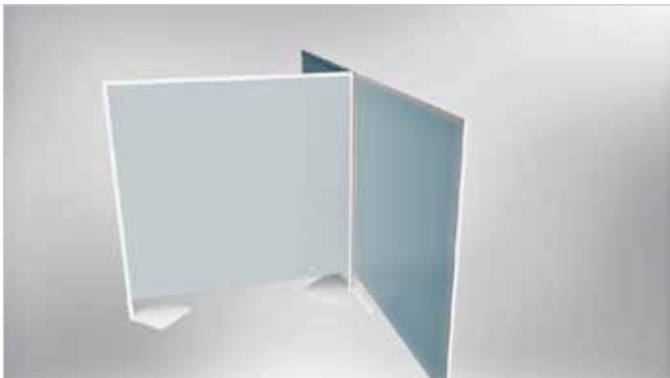

5-10 Days



POA



POA

Certifications:

- ISO 9001 2015
- CHAS
- Safe Contractor
- SMAS
- Greenlight



Swanmac

- ☎ 02920 811 458
- 🌐 <https://www.swanmac.co.uk>
- ✉ sales@swanmac.co.uk

Temporary Privacy Screen >

Key Features:

- Fast set up on site (approx. 2 mins)
- Easily Manoeuvrable once made up
- These are being manufactured at 2200mm length (bed length) and at 2100mm height
- Standard fixed cubicle tracking is also at 2100mm; therefore, this product should work seamlessly with existing cubicle track bed layouts, whilst removing the need for permeant fittings AND providing flexibility
- White PPC finish to all profile, clean with regular detergents, dustcover strip is inherently anti-microbial
- Tool requirements - only 1 x PH2 screwdriver/cordless, 4 x 25mm screws are provided. Approx. set up time per unit is 2 mins.
- FR Disposable Curtain in NHS blue (provided)
- Track compatible with all types of disposable curtains



5 Days



+ VAT
£290.00
Per Screen



Included

Certifications:

ISO 9001 2015

**Kensington Systems Ltd**

0117 9589933

<https://www.kensingtonsystems.co.uk>

sales@kensingtonsystems.co.uk

Room divider and cubicle track systems/disposable cubicle curtains >

Movatrack cubicle rail systems for room divider applications, shower tracks and privacy screens, great for creating additional bed spaces whilst retaining privacy. The system is either silver anodised aluminium or powder coated white and comes complete with quick curtain removal points to allow efficient replacement of curtains.

Can also be used as Intravenous drip systems with a range of telescopic carrier trees available in four sizes; all have simple release adjustment for accurate height control of the five stainless steel hooks.

Pump carriers have a 20mm diameter pole to which syringe and infusion pumps may be clamped; can be used alone for syringe pumps, or positioned alongside a carrier tree for infusion use, and with a load capacity of 30kg will take up to four pumps with ease.

The optional pump carrier with power supply solves the problem of cable management, with an NHS specification supply cable attached to the top of the pump carrier and across to the wall at ceiling height.

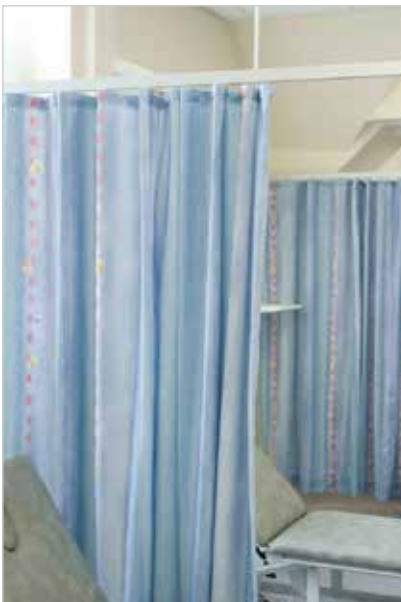

2-4 Weeks



POA



POA

Certifications:

ISO 9001 2015



Kensington Systems Ltd

☎ 0117 9589933

🌐 <https://www.kensingtonsystems.co.uk>

✉ sales@kensingtonsystems.co.uk

Spaceshade canopy systems >

Spaceshade canopies are an aluminium modular canopy system designed for creating covered outdoor spaces for:

- Dining
- Relaxation
- Creating equipment storage space to free up buildings and rooms for beds
- Walkways between buildings
- Decontamination facilities

The modular nature of the product enables fast installation without the need for heavy plant often associated with steel constructions. Spaceshade can also be fitted with our Enclosahade motorised screen to allow outdoor space to be protected from the elements as well as lighting and heating to make it truly versatile and cost effective additional space. Comes in a number of RAL colours to match the surrounding environment.



2-4 Weeks
Approx



POA



POA

Certifications:

ISO 9001
ISO 14001



Ezi Klamp Systems Ltd

☎ 0117 970 2420
 🌐 <https://www.eziclampsystems.com>
 ✉ sales@eziclampsystems.com

Ezi Klamp Free Standing Demarcation Barrier >

The Ezi Klamp Demarcation Barrier is the solution to help form queuing lanes to ensure visitors and staff are kept at a safe distance. The barrier is completely free standing and is tested to withstand high windspeeds (105mph), so barrier layouts won't be destroyed by strong gusts.

The barrier is simple to set up and large runs can be installed quickly, but also is able to be quickly reconfigured if site situation changes.



1-3 Days



POA



POA

Certifications:

- ISO 9001 2015
- CHAS
- Safe Contractor
- SMAS
- Greenlight



REGAL BALUSTRADES LTD

- ☎ 0117 9353888
- 🌐 <https://www.regalbalustrades.co.uk>
- ✉ sales@regalbalustrades.co.uk

CONVERTADEK >

CONVERTADEK is an innovative interchangeable trolley system for the medical profession. The top DEK can easily be removed to create various work platforms depending on your requirements.

Key Features:

- Comes with removable body DEK
- Interchangeable DEK options depending on your requirements
- Powder coated to RAL 9003 (white)
- Other RAL colours available on request
- Medical grade castors (2 locking swivel and 2 swivel)
- Fixed height trolley (900mm o/a)

Dimensions: 2076mm x 571mm (including end handles)

Extra options: DEK rails – POA

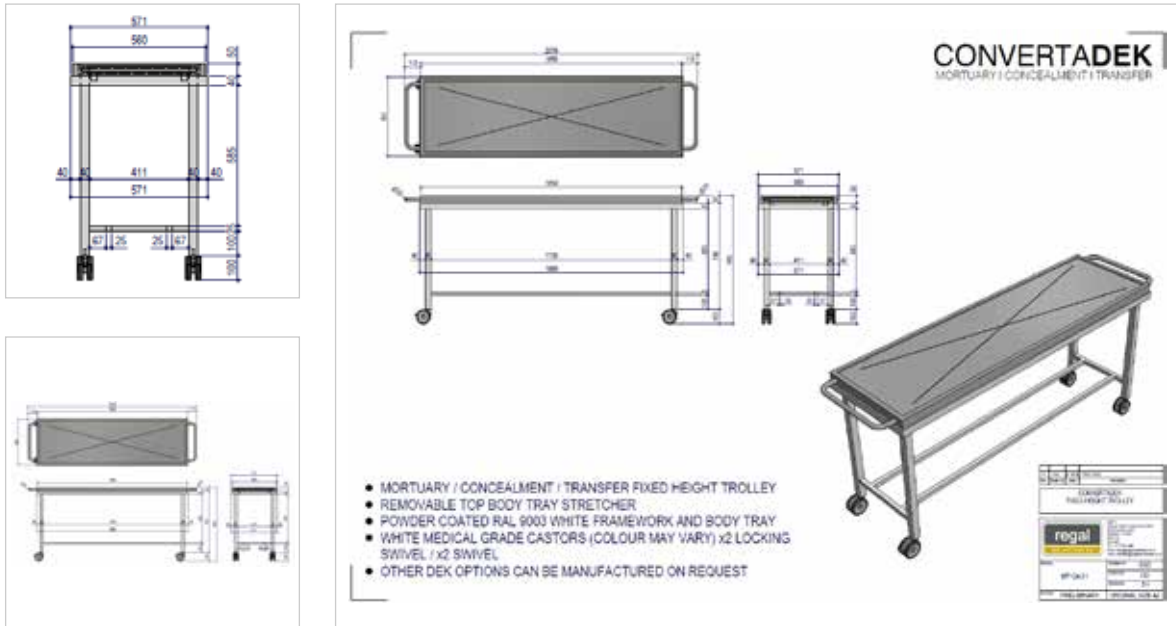



Decorquip Ltd

☎ 02920 880 811
🌐 <https://www.decorquip.com>
✉ sales@decorquip.com

Body bags

Key Features:

- Linear enforced 2 ply material
- 130 Micron
- Size: 230x90cm
- Fastens with a straight zip for added protection when infectious diseases are present



Image Available on Request



2-3 Weeks



each (+VAT)
£18.50
Min Qty 250



£15
Per pallett

Certifications:

ISO 9001
ISO 14001



Unisan Ltd

☎ 0330 700 6000
 🌐 <https://www.unisanuk.com>
 ✉ sales@unisanuk.com

 **Longopac Continuous Liner System >**

Never has hand hygiene and infection control been so important. Touching the top of waste bins and liners can be very unhygienic and a source of cross contamination.

Improve hygiene standards and infection control and reduce risk of contamination with **Longopac Continuous Liners.**

- No hand contact with the waste or top of the bin. All emptying and relining is done beneath the bin and outside of the waste
- Contain viral waste safely and quickly after every procedure
- Reduce plastic usage and carbon footprint with bin liners by up to 70%. Save time and labour emptying bins by up to 38%
- Used in many UK hospitals

Watch our [Hygiene & Safety](#) video | Watch our [Time Saving](#) video



1-2 Days



POA



POA

Certifications:

ISO 9001
ISO 14001



Unisan Ltd

☎ 0330 700 6000
 🌐 <https://www.unisanuk.com>
 ✉ sales@unisanuk.com

Hand & Surface Sanitiser stations >

Key Features:

- Mobile with wheeled base
- With Longopac Mini continuous liners - improve hygiene, reduces plastic usage, saves time
- Click [here](#) to see how the Longopac liners improve hygiene cross infection control
- With internal storage for sanitiser sprays & cleaning equipment
- Lockable doors available POA
- With centrefeed paper towel dispenser
- With refillable hand sanitiser dispenser
- White or dark grey

Contact us for price and lead times.

NB: We have stocks of hand & surface sanitiser and hand towels.



POA



POA



POA

Certifications:

ISO 9001
ISO 14001



Unisan Ltd

☎ 0330 700 6000
 🌐 <https://www.unisanuk.com>
 ✉ sales@unisanuk.com

ProfilGate Aqua - Mobile Footwear Sanitiser Station >

ProfilGate Aqua Mobile – The Smart Sanitising Entrance Solution
 Eliminating the risk of viral transfer via soles of shoes which can in turn be carried deeper into a facility, also avoiding transfer from shoe to hand during footwear change over.

Key Features:

- Automatic Sole & trolley wheel sanitisation & cleaning
- Mobile for rapid deployment
- Temporary sanitisation entrances
- Fire alarm/drill re-entry points
- Can be used either dry or with sanitising fluid
- Controlled application with inlet and outlet points
- Liquid level control for wet or light dampening
- A single unit built for the life of your facility!

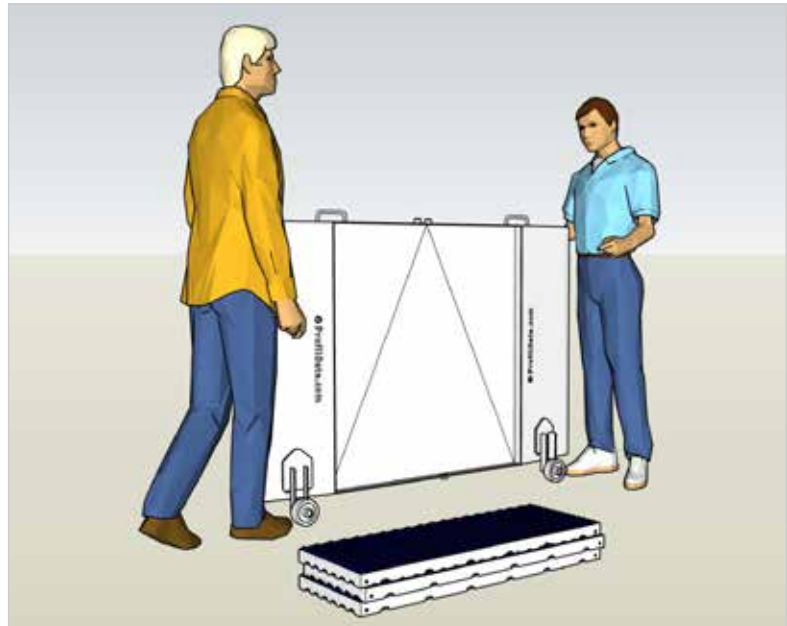
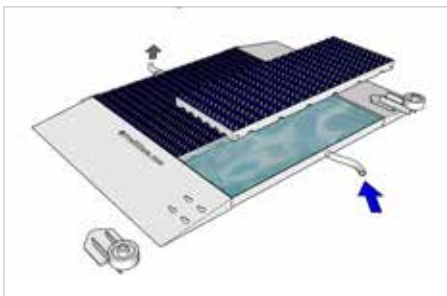
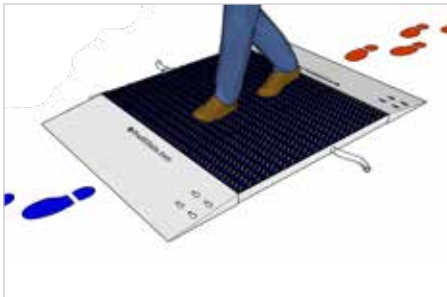



Medaco

☎ 033 33 22 33 44
 🌐 <https://www.medaco.co.uk>
 ✉ sales@medaco.co.uk

Emergency Field Bed >

Key Features:

- Fixed height
- Rapidly deployable
- Manual raising back rest
- Removable side rails and head/foot ends
- Mounted on castors (not shown on image)
- IV pole
- Delivered flat packed
- **Option:** Can be mounted on castors

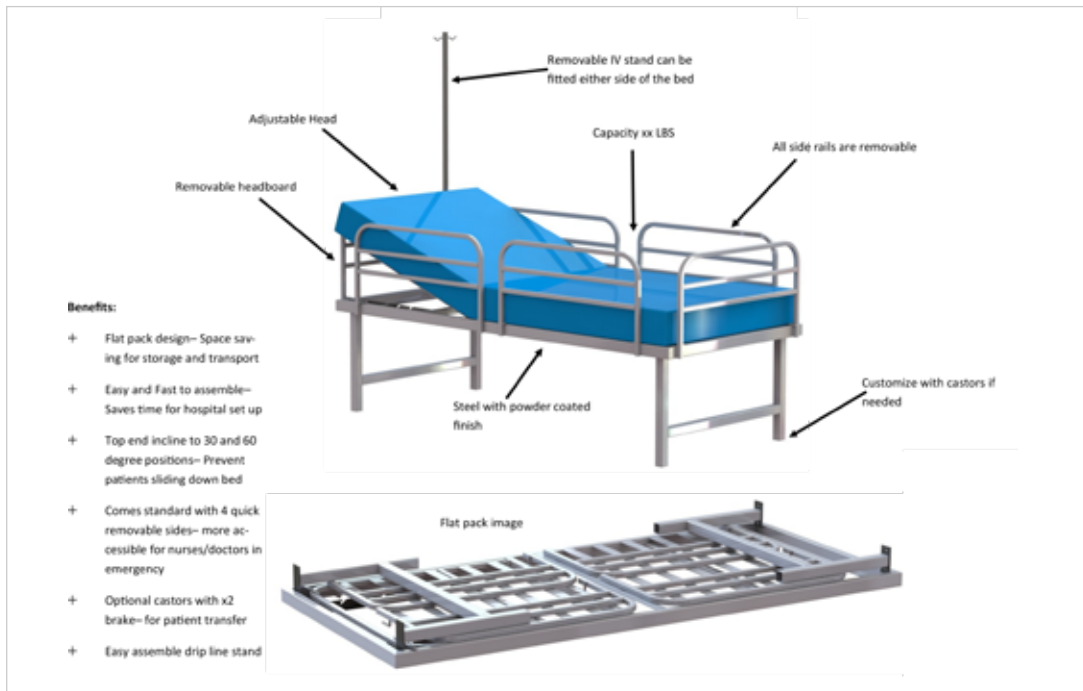

1-2 Weeks



POA



POA



Medaco

033 33 22 33 44
<https://www.medaco.co.uk>
 sales@medaco.co.uk

Casa Med Classic Nursing Bed >

Casa Med Classic FS Bed with Side Rails is our best-seller due to its beautiful finish with enclosed motors and a curved wooden head and foot board. The bed is adjustable in height between 40cm – 80cm (16” – 31”), enabling carers / nurses to care for users successfully, without bending and causing back injuries.

Key Features:

- 4 section profiling mattress support
- Height adjustment from 40cm – 80cm
- Safe working load 140kg (22 stone)
- Dewert actuator system and 8 button handset as standard
- Wooden headboard, footboard and full-length side rails



1-2 Weeks



POA



POA



Medaco

033 33 22 33 44
<https://www.medaco.co.uk>
sales@medaco.co.uk

Casa Med Low Nursing Bed >

The Casa Med Low FS Bed with Side Rails is a very good quality and reliable low profiling bed, designed for use in the home with an excellent height adjustable range, and including as standard many features normally only found on more expensive profiling beds, such as fully enclosed wooden bed ends and dual motor operation. Suitable for use in the domestic or residential care environments.

Key Features:

- 4 section profiling mattress support
- Height adjustment from 23cm - 63cm
- Safe working load 140kg (22 stone)
- Dewert actuator system and 8 button handset as standard
- Wooden headboard, footboard and full-length side rails



1-2 Weeks



POA



POA



Medaco

033 33 22 33 44
<https://www.medaco.co.uk>
sales@medaco.co.uk

Bariatric Profiling Bed – Pro Bario >

Pro-Bario is an electrically powered, bariatric bedframe that offers excellent value for money. Its wooden design differentiates it from acute style clinical bariatric beds, whilst providing all the innovative design and safety features required for high quality bariatric support and care.

With an adjustable height range of 20cm to 60cm, Pro-Bario is one of the lowest profiling bariatric care beds on the market. Designed to minimise the risk of falls and enable ease of access for the end user and carer, the bed offers a safe working load for up to 260 KG (41 stones) or 325 KG (51 stones) with the Bario-Max.

Key Features:

- Width: 120cm
- Length of lying platform: 200cm
- Extension Available: Yes (20cm)
- Height: 20cm - 60cm
- Safe Working Load: 260kg (41 stone) 325kg (51 stone)
- Electrical height adjustable: Yes
- Electrical Back Rest: Yes
- Electrical Knee Break: Yes
- Manual Raised Leg Section: Yes
- Trendelenburg/ Anti-Trendelenburg: Yes



1-2 Weeks



POA



Delivery, set up & commissioning - POA



WSG Interior Systems Limited

 07990080262
 <http://www.wsginteriors.co.uk>
 r.anderson@wsgsystems.com

Bedside Cabinet >

Key Features:

- Compact bedside cabinet
- 494mm Wide x 467mm Deep x 912mm High
- White MFC carcass with light grey doors
- One lockable fold down top box with double door cupboard below, including adjustable shelf.
- Four 65mm high quality casters - two lockable

Alternative colours available on request.



POA



£132.00
Less than 100 - POA



POA



Medaco

☎ 033 33 22 33 44

🌐 <https://www.medaco.co.uk>

✉ sales@medaco.co.uk

Disposable Patient Slings >

This polyester material option is specifically developed for single patient use, helping to reduce the risks of cross infection. Slings made from this fabric must not be laundered or exposed to water in order to maintain their integrity. Available on selected models only.

Key Features:

- Padded leg sections for increased comfort
- Colour coded binding indicates sling size
- Coloured attachment loops promote correct/safe positioning
- Sold in single units



1-2 Weeks



POA



POA



Medaco

033 33 22 33 44
<https://www.medaco.co.uk>
sales@medaco.co.uk

Liko 200 Ceiling Track Hoist >

The Likorall 200 overhead lift system is an ideal choice for those who want to have a cost-effective motor that fulfils everyday needs of safe and functional lifting. Safety features include a patented safety drum with speed limiter and electrical emergency lowering. The motor's 180 cm (72") lifting interval handles lifts from the floor in most environments, and the motor can be equipped with a special carriage for easy room-to-room transfers.

Key Features:

- 200kg Safe Working Load
- 2 Function (manual traverse)
- Electrical Emergency Lower
- Lifting interval 180cm
- Patented safety drum with speed limiter
- Charging via Hand control
- Wall parking station for sling bar
- Quick release sling bar
- Different sized sling bars (optional extra)
- Soft start/stop



1-2 Weeks



POA



POA



Medaco

☎ 033 33 22 33 44
 🌐 <https://www.medaco.co.uk>
 ✉ sales@medaco.co.uk

FreeSpan Gantry Hoist System >

FreeSpan™ Straight Rail is a flexible solution for most transfer situations. The lift system is freestanding, and since it is not affixed to the building structure, there are no special strength requirements for walls and ceiling.

FreeSpan Straight Rail is made of aluminium, many different rail lengths are available and it can be fitted with different Likorall lift motors.

The FreeSpan Straight Rail system is equipped with lockable wheels that improve positioning for specific tasks and enable portability of the system.

Available in single rail, or room covering designs, and Bariatric options available



1-2 Weeks



POA



Delivery, set up & commissioning - POA



Medaco

☎ 033 33 22 33 44
 🌐 <https://www.medaco.co.uk>
 ✉ sales@medaco.co.uk

Advance Mobile Hoist >

The 'Advance' is a Compact electric hoist that is exceptionally versatile and capable. Compact and nimble this hoist is able to lift from the floor and the added benefit of the 'Swan neck' leg design means that you can get close to wide obstacles. There is also an option of a 4-point positioning cradle providing care staff with a greater choice of sling systems. Compact and will split into 2 parts easily for transportation.

Key Features:

- Max user weight - 155kg (24 stone)
- Foldable (no tools necessary)
- Lifting Range 390-1690mm
- Total Weight 31.7kg
- Max Length - 1300mm
- Max Width (legs closed) - 670mm
- Max Width - Legs Closed - 685mm
- Compatible with loop fixing slings only
- Suitable for lifting from the floor



POA



POA



Delivery, set up & commissioning - POA



Medaco

033 33 22 33 44
<https://www.medaco.co.uk>
sales@medaco.co.uk

Journey Standaid >

The Oxford® Journey lift is an ultra compact, portable folding stand aid with best-in-class functionality. It is compact and lightweight allowing care-givers to manoeuvre in tight spaces and can be folded for easy storage or transportation. The unique adjustable cow-horn mechanism supports a wider range of patient heights and sizes, allowing your facility to have one lift that meets the needs of many.

Key Features:

- Safe working load 155kg / 24st / 342lbs
- Compact folding design for easy storage and transportation
- Unique adjustable cow horn function accommodates a range of patient sizes
- SmartTM Monitor diagnostic and service controls as standard
- Ergonomic design considerations and interaction points
- Height adjustable knee pad with retractable safety belt
- Removable foot tray for walking/rehabilitation activity



2-3 Weeks



POA



POA



Medaco

☎ 033 33 22 33 44
 🌐 <https://www.medaco.co.uk>
 ✉ sales@medaco.co.uk

Glideabout Commode >

The Glideabout commode is designed with a stable, robust frame made from powder-coated steel. The Glideabout comes with a high corrosion protection and space-saving push bar for optimal positioning over the toilet. Swing away armrests and footrests are included as standard. Also, with stable commode seat with integrated toilet pan holder.



POA



£94.00



POA



Medaco

 033 33 22 33 44
 <https://www.medaco.co.uk>
 sales@medaco.co.uk

Ben NH Car Transit Wheelchair >

The Ben NG is the entry level chair in the manual wheelchair range. Combining a reliable and proven construction with a modular concept that will allow you to reconfigure the propulsion type within a few minutes. Attendant and occupant propelled versions are available both in standard and heavy-duty versions.



POA



£228.00



POA



Medaco

☎ 033 33 22 33 44
🌐 <https://www.medaco.co.uk>
✉ sales@medaco.co.uk

Deluxe Drip Stand >

Key Features:

- Heavy base with 5 anti-static castors
- Head with 4 hooks
- Height adjustable: 120-220cm
- Base size: 56x56cm



5-7 Days



£79.00



POA

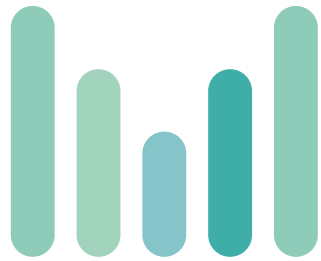

MEDACO[®]

support | equip | service

COVID-19 Healthcare Supplier Directory April 2020

 033 33 22 33 44

 <https://www.medaco.co.uk>

 sales@medaco.co.uk



Disclaimer

Please be aware that the availability and prices of products mentioned within this directory may be subject to change. If you require any further information please contact the relevant supplier. We will do all we can to help.